

# VIBRATION MANAGEMENT CORPORATION

5930 THOMAS ROAD , HOUSTON , TEXAS 77041 , U.S.A

INTERNET ADDRESS: [www.vimco.biz](http://www.vimco.biz)

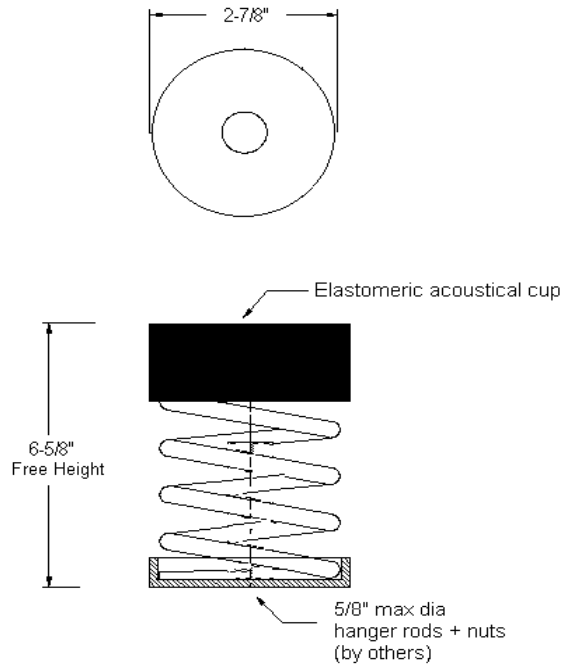
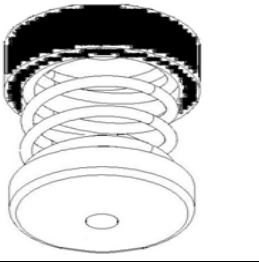

ISOLATOR MODEL	RATED LOAD (lbs)	SOLID LOAD (lbs)
OHSD-181	86	130
OHSD-182	133	200
OHSD-183	180	270
OHSD-184	266	400
OHSD-185	486	730
OHSD-186	713	1070
OHSD-187	926	1390
OHSD-181-199	593	890
OHSD-182-199	633	950
OHSD-183-199	683	1025
OHSD-184-199	783	1175
OHSD-185-199	933	1400
OHSD-186-199	1233	1850
OHSD-187-199	1460	2190

### FEATURES

\* Spring elements color-coded for easy field verification

### NOTES

1. Springs have 50% additional travel to solid beyond rated load.
2. Isolators should be selected in the range of -30% to +25% of rated load.
3. Consult spring chart for isolator performance data.
4. Nuts, washers & rods by others.

Notes / Remarks :

Project :  
Client :  
Consultant :  
Representative :

Title :

**OHSD**  
Open Spring Hanger  
(3" deflection)

Drawing no.  
**S-2125.21**

Rev. 0