

# VIBRATION MANAGEMENT CORPORATION

5930 THOMAS ROAD , HOUSTON , TEXAS 77041 , U.S.A

INTERNET ADDRESS: [www.vimco.biz](http://www.vimco.biz)



**DESCRIPTION:** VIMCO self-adhesive hanger pins are insulation hangers with a self-stick base. They are designed to adhere insulation to clean metal surfaces.

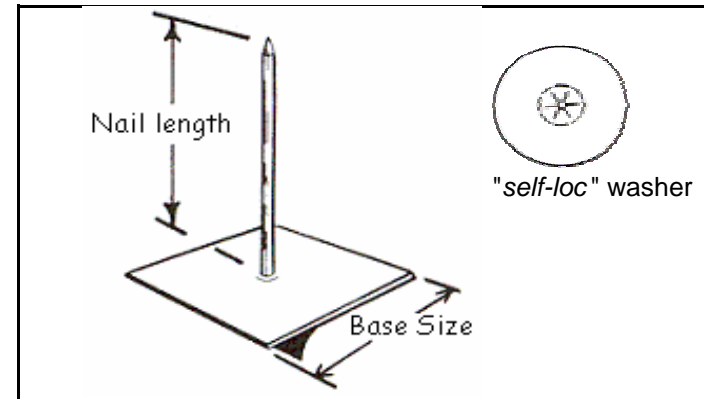

### MATERIAL OF CONSTRUCTION

NAIL	SCT: Copper coated steel, threaded SCP: Copper coated steel, plain SST: Steel, threaded SSP: Steel, plain ACT: Copper coated aluminum, threaded ACP: Copper coated aluminum, plain AAT: Aluminum, threaded AAP: Aluminum, plain
BASE	Galvanized steel sheet with pressure sensitive self-adhesive film protected by wax paper
WASHER	Galvanized steel sheet

### INSTALLATION INSTRUCTIONS:

1. Ensure metal surface is flat, smooth, clean and dry.
2. Remove release wax paper. Do not touch adhesive surface with fingers.
3. Press firmly onto base, pressing straight down.
4. Position insulation over pins, and press until insulation sets against base
5. Fit "self-loc" washers to the pins and press up to insulation surface.  
(Do not compress insulation)
6. Overhang length of steel nails should be cut off. Overhang length of aluminum nails can be bent by hand or cut off.

### How to Order:

<b>SCT - 1515 - 07</b>	
Nail Material	Nail Length
SCT	07 - 3/4"
SCP	10 - 1"
SST	12 - 1 1/4"
SSP	15 - 1 1/2"
ACT	17 - 1 3/4"
ACP	20 - 2"
AAT	25 - 2 1/2"
AAP	Base Size
	1515 - 1 3/8" x 1 3/8"
	2020 - 2" x 2"

Notes / Remarks :

Project :  
Client :  
Consultant :  
Representative :

Title : **Self-Adhesive Hanger Pins  
with "self-loc" washers**

Drawing no.  
**S-2800.01**

Rev. 1